

nº	Descripción
1	Junta tubular
2	Filtro HEPA
3	Enclavamiento
4	Turbina
5	Display temporizador
6	Botón paro emergencia interior
7	Sensor de presencia
8	Pantalla programación
9	Botón paro emergencia exterior
10	Filtro G4 con rejilla protección

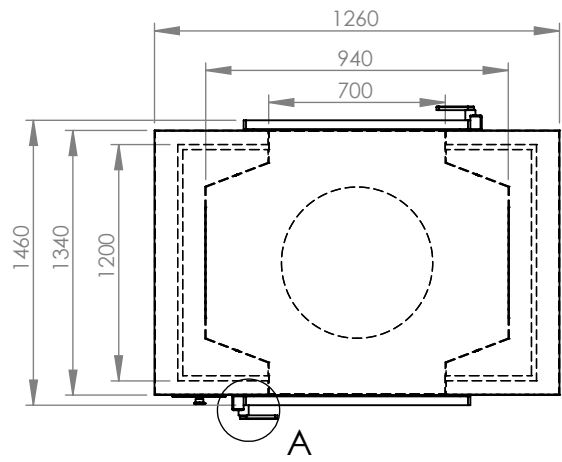

SI NO SE INDICA LO CONTRARIO: LAS COTAS SE EXPRESAN EN MM ACABADO SUPERFICIAL: TOLERANCIAS: LINEAL: ANGULAR:		ACABADO:	REBARBAR Y ROMPER ARISTAS VIVAS	NO CAMBIE LA ESCALA	REVISIÓN
DIBUJ.	M.Massaguer	FIRMA	FECHA	 TÍTULO: Cabina ducha de aire DAR.CD.AIELEC.1000	
VERIF.	D.Manzanares				
APROB.					
FABR.					
CALID.					
MATERIAL:			N.º DE DIBUJO		A4
A-304			MM-005-17		
PESO:			ESCALA: 1:50		HOJA 1 DE 1